



Heat-insulated containers AQUAFOOD are widely used in the food industry. The containers are made of food polyethylene of foreign make. Specially designed technology of double walls with heat-insulating foaming filling agent allows using these containers for pickling, storing and transportation of perishable foodstuffs, particularly of dairy products, meat products and fish products.

The containers design, which takes into consideration the consumers' requirement to this type of products, provides the products easy storing (the channels for forklift runners are previewed), transportation and usage.

There is a drain hole with a lid in the bottom of the container for liquids and sediments discharge.

In the nearest future Aquatech plans to noticeably extend the range of heat-insulated containers.

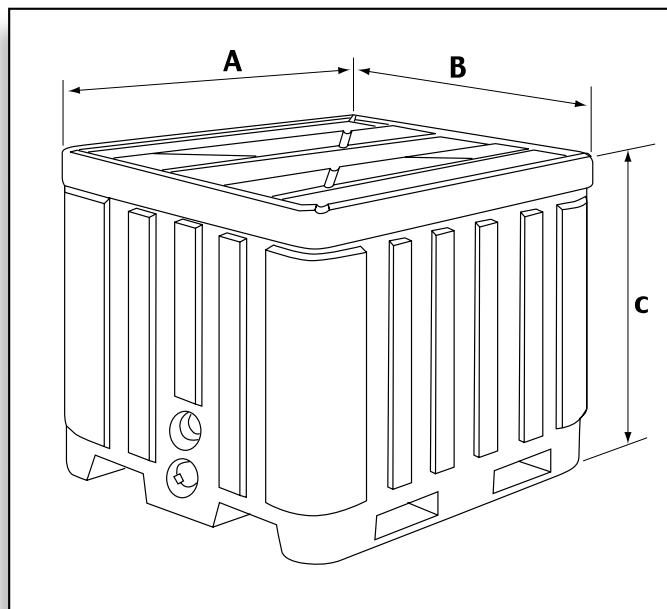

Product name	Length, mm	Width, mm	Height, mm	Net volume, l
Heat-insulated container	1200	1088	944	1200